

# SA FIRE DOOR BROCHURE



**SA FIRE DOORS®**  
STABILITY • INTEGRITY • LONGEVITY

[www.safiredoors.co.za](http://www.safiredoors.co.za)

## SA FIRE DOORS

Manufacturers and installers of high quality & durable fire rated doors. We offer turnkey solutions to the commercial, residential and construction industry. We offer complete door solutions and cater to specified projects.

## THE PURPOSE OF FIRE DOORS

A fire door is a vital safety component of any building or structure. The occupancy of a building is reliant on fire resistant doors that are specified by engineers. Its purpose is not only to protect the building, but to give occupants a chance to evacuate safely in the event of a fire. The guidelines set out by SANS 1253:2016 clearly defines the constituents of the door to which SA Fire Doors adhere to without compromise.

## OUR FIRE DOORS

The design and manufacturing process of our doors has been carefully engineered through continued research and development to ensure that the core of our doors maintain its stability and integrity. This results in superior performance across the board, with doors surpassing testing criteria for stability, integrity and insulation.

All our doors are made up of high quality noncombustible core that varies across the various Classes to ensure that the door performs in the event of a fire. The core of our doors are fully described in our testing reports.

SA Fire Doors have test reports to supply Class A and E doors in both single and double doors. All our doors are supplied in steel frames. Our Class A and E doors are edged with hardwood edging. We are busy with further product development and in the process of testing Class B doors.

All doors are supplied with a 3mm MDF finish suitable for painting. We however cater to the clients needs and can supply doors with a variety of veneer finishes. We recommend that external fire doors, or doors used in an environment where its exposed to hard wear, are clad with steel.

SA Fire Doors frames are manufactured with 1.6mm pre-galvanised steel for our Class A and E doors. Our rebates for all our steel frames are 25mm x 50mm. As per SANS 1253:2016 regulation a fire frame must have a minimum rebate of 25mm and a minimum steel thickness of 1.5mm.



Our frames are manufactured to the specific needs of each project and can accommodate all wall thicknesses and fixing methods. Frames are supplied in either a single or double rebate.

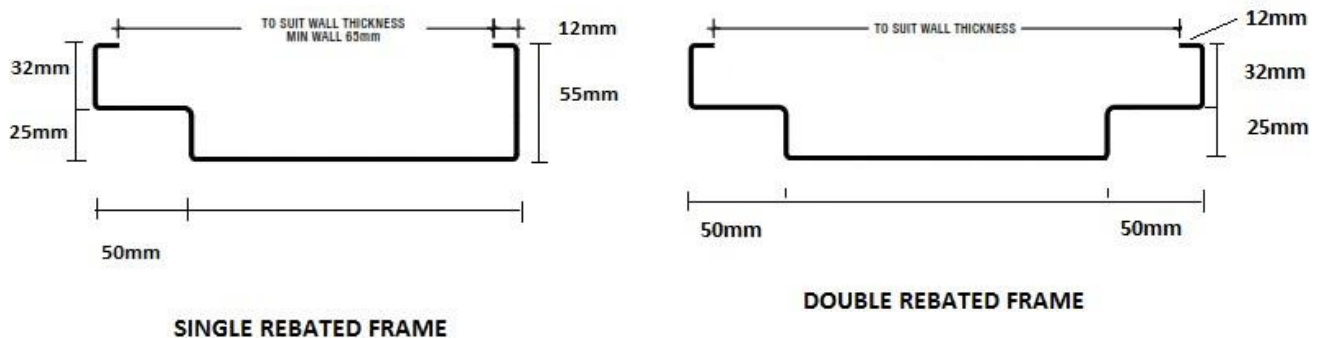

## FIXING METHODS

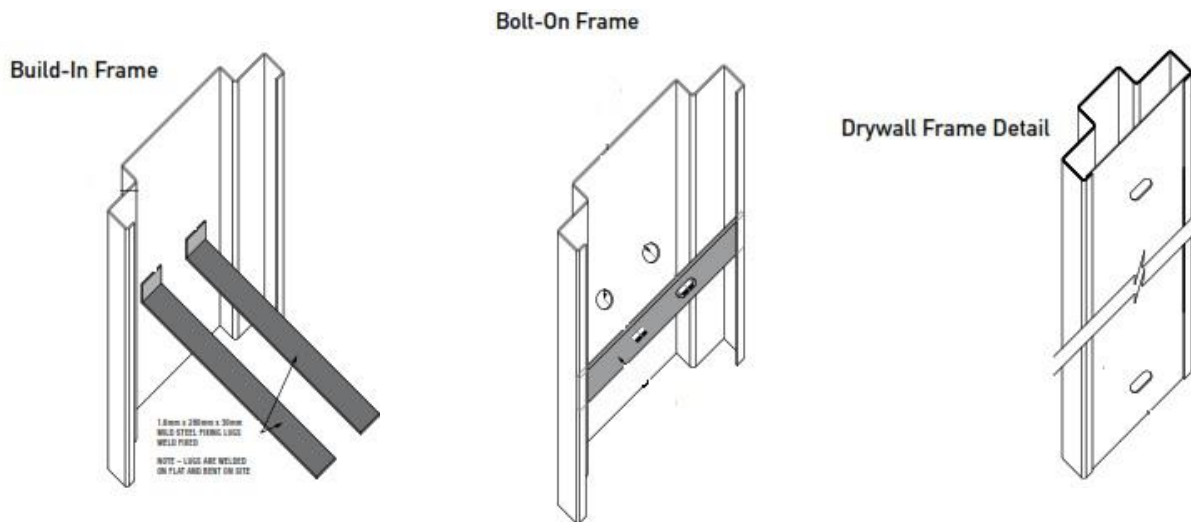

## HAND OF DOORS

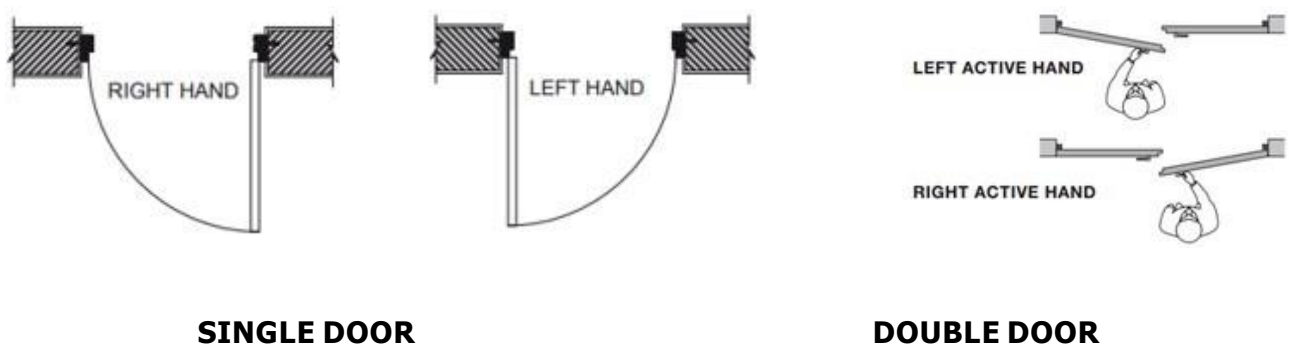

Stand in front of the door with the door leaf pulling towards you. The hand of a single door is determined by the side the hinges are fitted.

Stand in front of the door with the door leaves pulling towards you. The hand that pulls the door leaf determines the “hand” of the door.

# SANS 1253:2016 REGULATION

MINIMUM RESISTANCE PERIOD IN MINUTES					
CLASS	STABILITY	INTEGRITY	INSULATION	IMPACT TEST	VIEW PANEL
A	60	30	30	Not Req	100x300
B	120	60	60	Not Req	100x300
C	120	120	Not Req	Not Req	100x300
D	120	120	120	Yes	Not Allowed
E	30	30	30	Not Req	100x300
F	30	30	Not Req	Not Req	100x300

## FIXING METHODS

When specifying fire doors it is important to specify your exact needs. By understanding your requirements, we are able to give better advise and deliver a product that suits your needs.

- Class of door
- Size of door
- Single or double leaf
- If double, equal or unequal leaf
- Type of wall
- Type of frame, e.g. lugs or bolt-on
- Wall thickness and finish
- Single or double rebate

When measuring an opening take three measurements across the width of the opening. At the top, middle and bottom. For the height of the opening take three measurements, on the left side, middle and right side of opening. Provide us with the smallest width and height measurements.





Visit our website for our interactive order form.

## CERTIFICATION



Regulation stipulates that all fire doors are supplied as a tested unit. All units are supplied with a unique serial tag. Each door leaf and frame must be fitted with a matching tag, indicating the supplier, Class of fire door and date manufactured.

## INSTALLATION

GAPS	MODIFICATION	INSTALLATION	IRONMONGERY	GUIDELINES
 <p><b>Single doors</b> Max 3mm gap between top of door &amp; frame. Max 6mm gap over total width.</p> <p><b>Double doors</b> Max 4mm between meeting styles. Max 4mm over total width.</p> <p><b>All doors</b> Min 5mm and max 12mm gap between door &amp; floor.</p>	 <p>Doors are made in size to fit their matching frames. Should resizing or adjustments be required, note that a maximum of 3mm may be removed on each side of door. Failure to adhere to this may compromise the structure and integrity of the door.</p>	 <p>Frames must be built in 100% plumb in order for door leaves to fit flush in the frame. All faces of the frame to be true and level and all corners 90 degrees. Frames to be caulked with mortar and allowed to cure for 3 days before doors are hung. Fire rated hinges supplied must be used.</p>	 <p>Ironmongery must be fire rated to suit the class of the door. Mortise locks shall not exceed 150mm in depth and 20mm in thickness. Each fire door is to be fitted with a self-closing device. Double doors must be fitted with a door selector / co-ordinator. No recessed hardware is permitted.</p>	 <p>All doors must have a nib / reveal no less than 50mm at the hinge side to prevent closers &amp; handles to bind against the wall. Door stops must be placed more than 150mm from leading edge of door and allow door to open at least 90 degrees.</p>

## CONTACT US

*Contact us for quotations, installations or advice.*

Email: [office@safiredoors.co.za](mailto:office@safiredoors.co.za)

Office phone: 087 265 4171

Website: [www.safiredoors.co.za](http://www.safiredoors.co.za)

Unit 23, N1 Industrial Park 16th  
Street

Elsies River 7490